

**Aviation Fabricators  
805 North Fourth Street  
Clinton MO 64735**

Document No: AF-570  
Revision: (B)  
Date: June 11, 2021

## ***INSTRUCTIONS FOR CONTINUED AIRWORTHINESS***

For

Aft Toilet Cabinet Seat Installation

**Document No.: AF-570**

**Revision "B"**

**Revision Date: 06/11/21**

**Applicable to:**

**Textron B300, B300C  
Series Aircraft**

**Modified by FAA STC SA02468LA**

The information in the Instruction for Continued Airworthiness is FAA accepted material and complies with 14 CFR 23.1529, Instructions for Continued Airworthiness. It supersedes or adds to that provided in the Maintenance Manual for B300 Series Aircraft, only where covered in the items contained herein. For limitations and procedures not contained in the Supplement, consult the Component Maintenance Manual, or other approved airplane data.

## ***REVISION PAGE***

Document Title:       Instructions for Continued Airworthiness

Prepared By: Todd Pogue

Updates to the ICA will be made by Aviation Fabricators Inc. Updates will be listed in the log of revisions and the effective pages will be listed below.

<b>Log of Revisions</b>				
<b>REV. NO.</b>	<b>EFFECTED PAGE(S)</b>	<b>DESCRIPTION</b>	<b>DATE</b>	<b>APPROVED BY</b>
IR	All	*Initial Release	10/30/13	JRL
A	5, 7, 11, & 12	*Changed P/N of Placard in Figure 8.0C to 15-0986 from 32-0210-40-1, pg. 12 *Added new Toilet Cabinet Seat P/N 32-0542 Ref to pages 5 & 7 as needed *In Section 5.0 corrected the maximum allowable seat weight to 49.0 lbs from 50.0 lbs, pg. 11	11/01/19	JRL
B	All	*Removed Section 13.0 Troubleshooting *Added P/N's 32-0545 & 32-0546, pgs 5 & 7 *Updated Figure 1.0A with Relief Tube illustration, pg 8 *Updated Section 10 Airworthiness Limitations to latest format, pg 16 *Added Task Code to table on pg 11 *Added line item 9.A.10. to clean relief tube, pg. 14 *Added "Relief Tube" paragraph on pg 15	06/11/21	JRL

## **TABLE OF CONTENTS**

<b>INSTRUCTIONS FOR CONTINUED AIRWORTHINESS</b>	<b>1</b>
<b>REVISION PAGE</b>	<b>2</b>
<b>TABLE OF CONTENTS</b>	<b>3</b>
<b>1.0 INTRODUCTION</b>	<b>5</b>
<b>2.0 INSPECTION REQUIREMENTS AND OVERHAUL SCHEDULE</b>	<b>10</b>
<b>3.0 DIMENSION AND ACCESS</b>	<b>11</b>
<b>4.0 LIFTING AND SHORING</b>	<b>11</b>
<b>5.0 LEVELING AND WEIGHING</b>	<b>11</b>
<b>6.0 TOWING AND TAXIING</b>	<b>12</b>
<b>7.0 PARKING AND MOORING</b>	<b>12</b>
<b>8.0 PLACARDS AND MARKINGS</b>	<b>12</b>
<b>9.0 SERVICE INFORMATION</b>	<b>13</b>
<b>10.0 AIRWORTHINESS LIMITATIONS</b>	<b>15</b>
<b>11.0 SERVICE INSTRUCTIONS FOR TOILET UNIT</b>	<b>16</b>
<b>12.0 SERVICE INSTRUCTIONS FOR OXYGEN SYSTEM</b>	<b>31</b>

## ABBREVIATIONS AND DEFINITIONS

<b>Abbreviations</b>	<b>Definitions</b>
FAA	Federal Aviation Administration
General Visual Inspection (GVI)	A visual examination of an interior or exterior area, installation or assembly to detect obvious damage, failure or irregularity. This level of inspection is made from within touching distance unless otherwise specified. A mirror may be necessary to enhance visual access to all exposed surfaces in the inspection area. This level of inspection is made under normally available lighting conditions such as daylight, hangar lighting, flashlight or droplight and may require removal or opening of access panels or doors. Stands, ladders or platforms may be required to gain proximity to the area being checked.
ICA	Instructions for Continued Airworthiness
STC	Supplemental Type Certificate

## 1.0 INTRODUCTION

The purpose of this Maintenance Manual Supplement and Instructions for Continued Airworthiness (ICA) is to provide the maintenance technician with the information necessary to ensure the continued airworthiness of the Aviation Fabricators aft toilet cabinet seat installation when installed in accordance with Aviation Fabricators design data included on Master Data List AF-482MDL and per Supplement Type Certificate (STC) SA02468LA.

Modifications to an aircraft obligates the operator to include the maintenance information provided by this document into the operators aircraft Maintenance Manual and operator's aircraft scheduled maintenance program. This document defines supplementary maintenance operations and frequencies recommended by Aviation Fabricators Inc., to ensure the aircraft's airworthiness.

The information contained herein addresses the requirements specified in 14 CFR 23.1529, Instructions for Continued Airworthiness and supplements the basic Airplane Maintenance Manual only in those areas listed as pertains to the installation of the aft toilet cabinet seat, as installed per the Aviation Fabricators Master Data List AF-482MDL. For limitations and procedures not contained in this supplement, consult the basic Airplane Maintenance Manual.

### DATA

All information to support the continued airworthiness of this modification is contained in:

STC SA02468LA.  
Master Data List: AF-482MDL.

Installation: Installation Instruction:  
D-10646 or D-10883

Oxygen System Drawings:  
D-10409 for Beech B300 series LH oxygen, air vent, and light system installation

Parts: P/N 32-0385, Aft Toilet Cabinet Seat Assembly  
P/N 32-0542, Aft Toilet Cabinet Seat Assembly  
P/N 32-0545, Aft Toilet Cabinet Seat Ass'y w/ Relief Tube  
P/N 32-0546, Aft Toilet Cabinet Seat Ass'y w/ Relief Tube

The aft toilet cabinet seat is attached to the aircraft floorboards with nutplates and bolts. The seat belt is attached to fittings attached to the floorboard on the inboard side of the seat and to bracket attached to the outboard sidewall. The shoulder harness assembly is attached through a loop fitting installed on the aft bulkhead. The toilet assembly in the toilet cabinet is wired into the existing aircraft system. An additional 3 mask oxygen container assembly is plumbed into the existing aircraft system in the aft section of the passenger cabin.

**Design Change Control**

All data and changes to the parts and assemblies will be tracked per Master Data List AF-482MDL Rev C or later approved revision.

**Applicable Aircraft**

Textron models B300 & B300C Series Aircraft

Aft Toilet Cabinet Seat Assembly  
P/N'S 32-0385, 32-0542, 32-0545, 32-0546

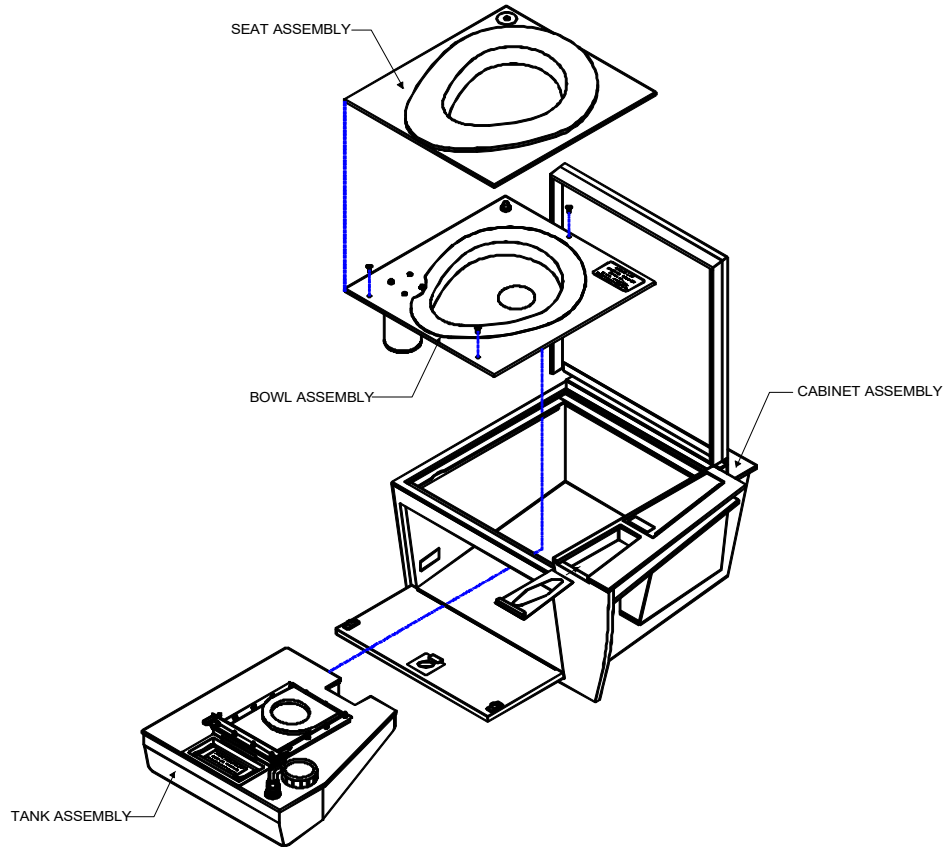

**Figure 1.0A**

Tank Installation

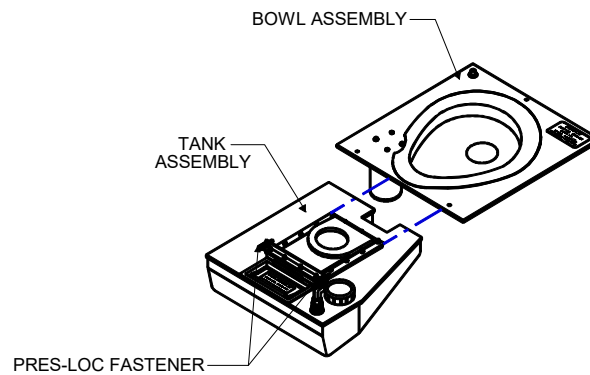

**Figure 1.0B**

Cabinet Seat Installation

P/N'S 32-0385K, 32-0542K, 32-0545K, 32-0546K

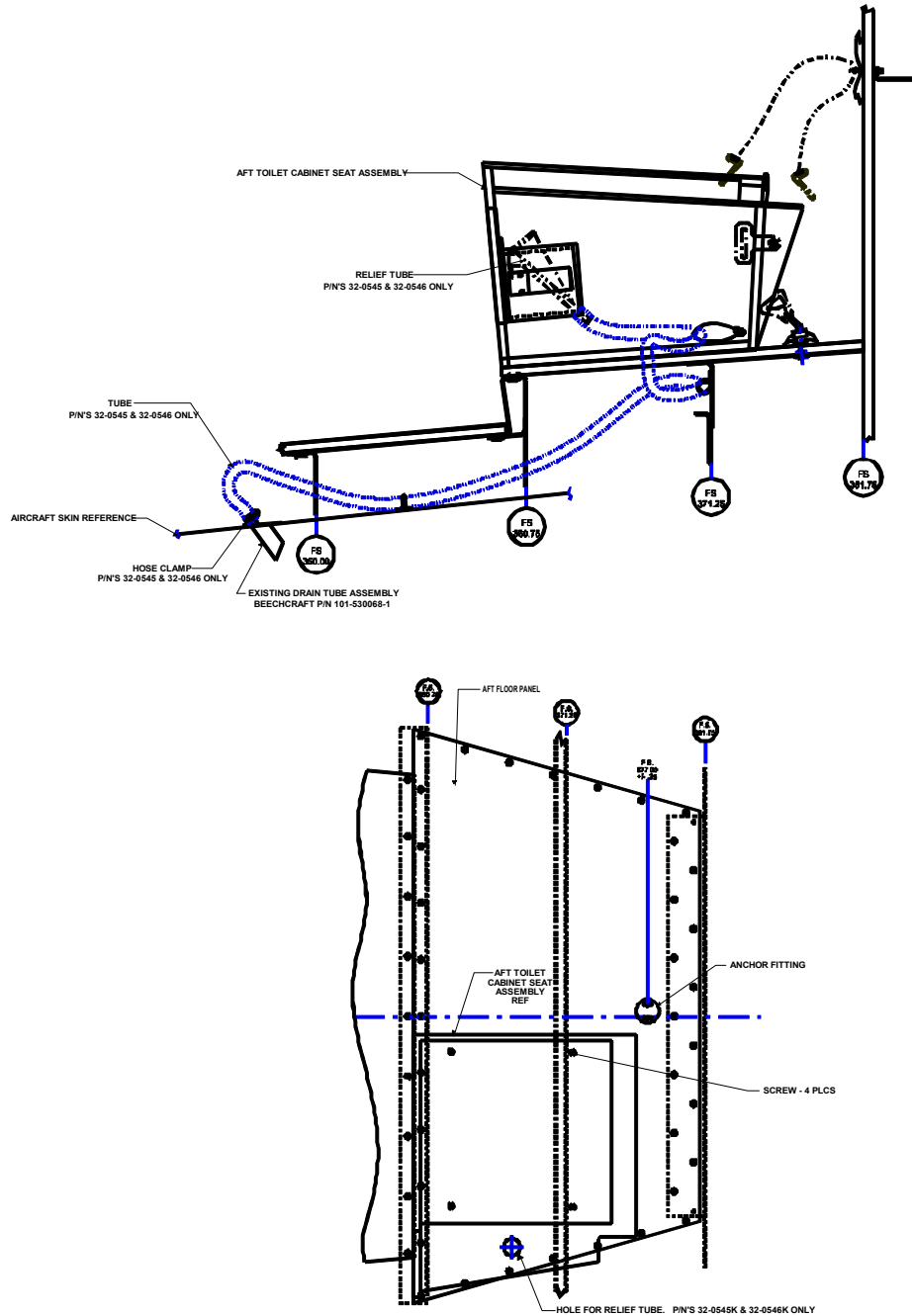
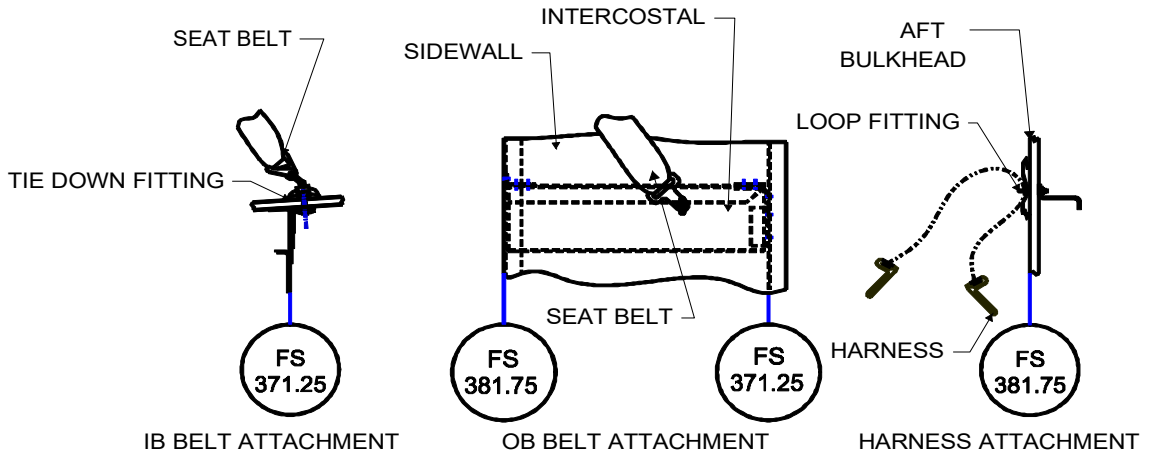

Figure 1.0C



Seat Belt /Shoulder Harness Attachment



**Figure 1.0D**

Cushions

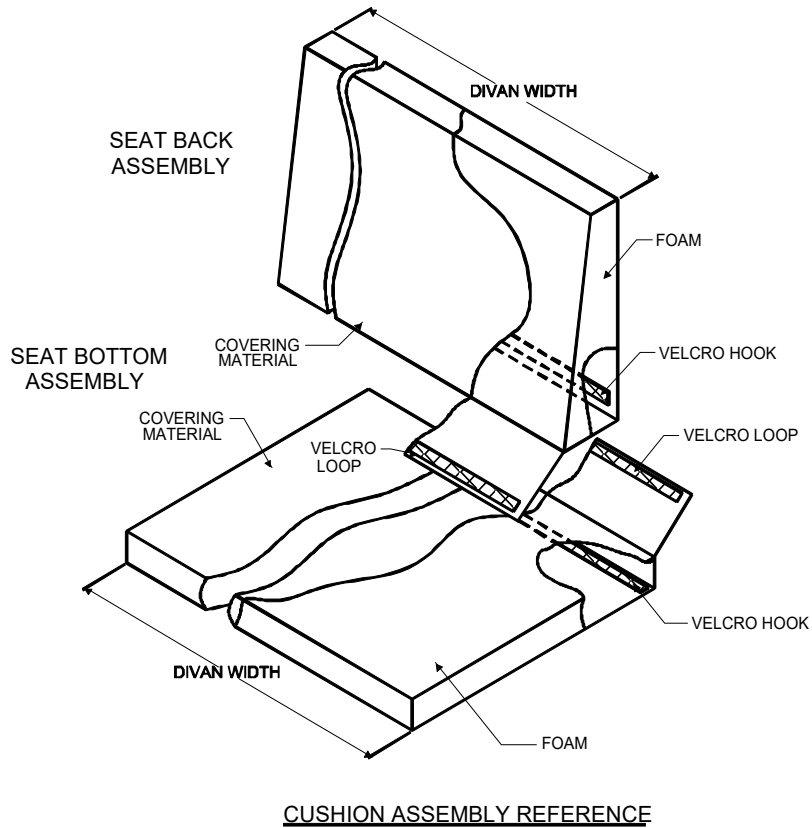

**Figure 1.0E**

## **2.0 INSPECTION REQUIREMENTS AND OVERHAUL SCHEDULE**

1. To comply with 14 CFR 23.1529, continue the new aft toilet cabinet seat, the additional 3 mask oxygen container assembly, and restraint system on the same inspection and maintenance schedule used per the applicable Beechcraft B300 Series Maintenance Manual for seats.
  - a. The aft toilet cabinet installation requires no service other than inspection at normal Phase 4 inspection schedule of 800 hours or 24 months whichever occurs first.
  - b. The additional oxygen container assembly is to be added to the normal aircraft inspection system at Phase 1 & 3 Inspection of 200 hours or 24 months whichever occurs first.

<b>Task Code</b>			<b>Schedule</b>	<b>Date</b>	<b>Mech</b>	<b>Insp</b>
AFI-100	a.	Perform a General Visual Inspection (GVI) for damage to upholstery.				
AFI-101	b.	Perform a GVI of the safety belts for wear, cuts, fraying, damage, and deterioration.				
AFI-102	c.	Perform a GVI of the safety belt attachment fittings for wear and damage				
AFI-103	d.	Perform a GVI of the attaching fittings for damage, security, and function.				
AFI-104	e.	Perform a GVI of the seat frame for damage, and corrosion.				
AFI-105	f.	Perform a GVI of the overall seat for fit and function.				
AFI-106	g.	Check operation of toilet assembly. See Section 11.				
AF-107	h.	Perform a GVI of the oxygen mask and container.				

AFI-108	i.	Function Test Oxygen Container assembly. See Section 12.				
AFI-109	j.	Perform a GVI of the relief tube and drain tube assembly for proper operation (if installed)				

- A. Continue the new aft toilet cabinet seat, and restraint system on the same inspection and maintenance schedule used per the Beechcraft Maintenance Manual for passenger seats.
- B. Continue the additional oxygen container assembly installation on the same inspection and maintenance schedule used per the Beechcraft Maintenance Manual for the oxygen system.
- C. Flushing toilet maintenance schedule:
  - 1. Service and clean after each flight when toilet is used.
  - 2. If the toilet is to remain inactive for an extended period of time, empty the water/chemical solution and thoroughly flush the system with fresh water, then drain the entire system.

### **3.0 DIMENSION AND ACCESS**

The installation of the aft toilet cabinet does not change the dimensions of the aircraft or alter the access to any existing aircraft system.

### **4.0 LIFTING AND SHORING**

No change.

### **5.0 LEVELING AND WEIGHING**

For the Flushing Toilet, the dry weight plus fluid will be used to conduct the aircraft weighing procedures for determining the empty weight of the aircraft:

Cabinet weight without any upholstery	=	15.5 lbs
Toilet weight	=	19.0 lbs
The additional fluid for the flushing reservoir	=	4.0 lbs
Total	=	<u>38.5 lbs</u>

The maximum allowable finished seat weight with seat bottom upholstery is 49.0 lbs.

## **6.0 TOWING AND TAXIING**

No change.

## **7.0 PARKING AND MOORING**

No change.

## **8.0 PLACARDS AND MARKINGS**

Up to 5 placards are required in conjunction with this modification:

1. Decal P/N 32-0328-40 is to be installed on the door of the lifevest compartment on the top side of the toilet cabinet.

LIFEVEST STORAGE  
PUSH TO OPEN

**Figure 8.0A**

2. Placard P/N 15-0779 is to be installed on the LH window panel in plain sight of the seat occupant.

FASTEN SHOULDER HARNESS  
AND SEATBELT DURING  
TAXI, TAKEOFF, AND LANDING.

**Figure 8.0B**

3. Placard P/N 15-0986 is to be installed of the aft bulkhead center line just above W.L. 119.0

COMPARTMENT CAPACITY  
TOTAL COMPARTMENT CAPACITY INCLUDING  
BAGGAGE AND OR PASSENGER NOT TO  
EXCEED 450 POUNDS.  
SEE WEIGHT AND BALANCE SECTION OF  
FLIGHT MANUAL FOR LOADING INSTRUCTIONS.

**Figure 8.0C**

4. Placard P/N 32-0210-23 is to be installed on the aft side of the LH aft divider in plain sight of the seat occupant.

NOTICE  
SHOULDER HARNESS  
MUST BE WORN  
DURING TAKE OFF  
AND LANDING

**Figure 8.0D**

## **9.0 SERVICE INFORMATION**

**Typical Aft Toilet Cabinet Seat Service Instructions:**

## **A. Upholstery Cleaning:**

### **Seat Service Instructions**

1. Remove seat back and seat bottom cushion assemblies from sidewall and divan top.
2. If possible dry clean fabric cushions.
3. If dry cleaning is not possible clean fabric with Armour All fabric cleaner or equivalent.
4. Clean leather with Armour All leather cleaner or equivalent.
5. Clean drawer finish using Armour All multi-purpose cleaner or equivalent.
6. Clean and inspect restraint system for damage, fraying, cuts or seam deterioration.
7. Inspect all attachment fittings and replace if necessary.
8. Inspect overall seat for fit and function.
9. Clean the relief tube assembly using soap and water.

## **B. Toilet Service Instructions:**

See Section 11.0

## **C. Oxygen System Service Instructions:**

See Section 12.0

### **Typical Aft Toilet Cabinet Seat Maintenance Instructions:**

#### **Aft Toilet Cabinet Seat Assembly:**

The seat assembly is a self-contained complete assembly that mounts to the existing aircraft aft floorboards using four standard bolts. Refer to Figure 1.0D.

#### **Aft Toilet Cabinet Seat Installation:**

The installation of the seat requires aligning seat over attachment holes and installing with four bolts.

#### **Aft Toilet Cabinet Seat Removal:**

Removal of the seat assembly requires loosening the attaching four bolts.

Cushions:

Seat back and seat bottom cushion assemblies are removed by simply pulling the cushion inboard away from the Velcro on the sidewall or up away from the Velcro on the lid of the seat assembly, respectively. All covering and upholstery materials must comply with 14 CFR 23.853 as stated on the installation instructions, D-10646. Refer to Figure 1.0E for Cushion Assembly Reference.

**Seat Belt:**

Seat belt removal is accomplished by loosening attaching hardware on outboard side of cabinet seat and unhooking the inboard fitting from the tie-down fitting. The shoulder harness is removed from the loop attached to the aft bulkhead. Refer to Figure 1.0B

**Relief Tube:**

The relief tube is installed in a drawer in the aft toilet cabinet seat. It is attached to tubing that is routed through a hole in the aft floorboard and then through the structure under the floorboards and clamped to an existing drain tube assembly.

**Typical Toilet Maintenance Instructions:**

See Section 11.0 for toilet maintenance instructions.

**Typical Oxygen System Maintenance Instructions:**

**Oxygen System:**

The passenger oxygen mask is an airline conical, constant flow type. When the system is actuated, the initial high pressure surge operates an actuator that opens the cover assembly. After the mask is removed from the container, a lanyard pin must be pulled from the mask valve. With the oxygen turned on, the mask supply tube contains a positive-flow indicator that is readily visible to the user when the mask is being worn. To shut off the flow of oxygen to the mask, install the lanyard pin in the mask valve.

See Section 12.0 for oxygen system maintenance instructions.

**D. RECOMMENDED OVERHAUL PERIODS**

No additional overhaul time limitations.

**10.0 AIRWORTHINESS LIMITATIONS**

The information contained herein supplements the basic Maintenance Manuals only in those areas listed, when the aircraft is modified in accordance with Aviation Fabricators Master Data List AF-482MDL Rev N or later approved revision. For limitations and procedures not contained in this supplement, consult the basic Airplane Maintenance Manuals.

The Airworthiness Limitations section is FAA approved and specifies maintenance required under Sec. 43.16 and 91.403 of the Federal Aviation Regulations unless an alternative program has been FAA approved.

AIRWORTHINESS LIMITATIONS - LOG OF REVISIONS			
REV.	EFFECTED PAGE (s)	DESCRIPTION of REVISION	DATE
(IR)	All	Initial Release	06/11/21

#### AIRWORTHINESS LIMITATIONS

There are no Airworthiness Limitations to the aircraft with the addition of the aft toilet cabinet assembly installed by this STC.

#### **Distribution:**

Per the requirement of Appendix G of 14 CFR Part 23 paragraph G23.1 (c), the changes made to the ICA by the applicant will be distributed via mail by means of paper copy.

## **11.0 SERVICE INSTRUCTIONS FOR TOILET UNIT**



MAINTENANCE MANUAL

MONO-LAV®  
AIRCRAFT TOILETS

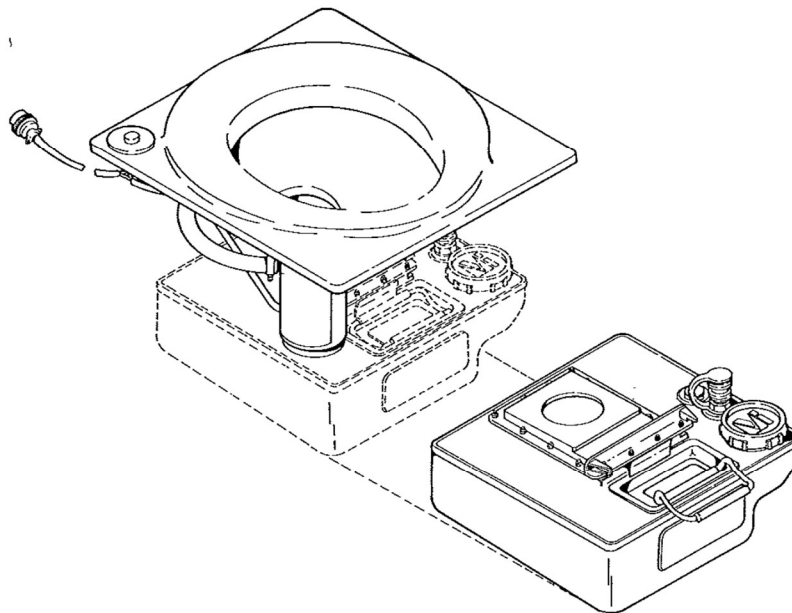

Monogram Sanitation

800 W. ARTESIA BLVD., COMPTON, CA 90224-9057

MM-170  
Nov 20/90

## Monogram Sanitation

### CONTENTS

<u>SECTION</u>	<u>PAGE</u>
Description and Operation . . . . .	1
Leading Particulars and Servicing . . . . .	3
Troubleshooting and Maintenance . . . . .	7

### ILLUSTRATIONS

<u>FIGURE</u>	<u>PAGE</u>
Typical Toilet Assy . . . . .	1
Wiring Diagram . . . . .	12

MM-170  
CONTENTS  
Nov 20/90

## Monogram Sanitation

### DESCRIPTION AND OPERATION

#### 1. General

This publication is issued to provide instructions for servicing and maintenance of MONO-LAV<sup>®</sup> Aircraft Toilet Assembly, manufactured by Monogram Sanitation, Compton, California. The unit is a light weight, compact, electrically operated flushing toilet which utilizes ordinary tap water and a germicidal deodorant, Monogram's Chemkare, as a flush fluid.

#### 2. Description

The recirculating flushing toilet is a completely self-contained unit requiring only the external connection of 24-28 volt DC electrical power. The toilet assembly is designed for permanent installation in the aircraft, requiring only the removal of the waste tank when servicing is desired.

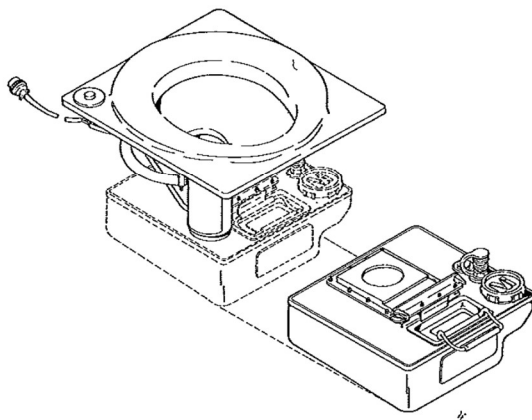

MONO-LAV<sup>®</sup> AIRCRAFT TOILET

## Monogram Sanitation

The toilet assy consists basically of a seat and shroud assembly which rests on the toilet mounting plate. Attached to the mounting plate are the polished stainless steel bowl assembly, the motor and pump assembly, and the PRESS TO FLUSH switch. Mounted to the bottom flange of the bowl is the slide assembly into which the removable tank assembly is installed.

The removable tank assembly consists of a storage tank on which the knife valve, flush line quick disconnect and carrying handle are located. Extending through the cover of the knife valve is a manually operated actuator to open or close the knife valve, sealing the tank contents prior to removal of the tank. The position of the knife valve may be observed through the opening at the bottom of the bowl.

The tank assembly detaches from the toilet at the front of the unit. Two Pres-Loc fasteners, one on each side of the knife valve, secure the installed tank in the sealed position against the bottom of the bowl. By detaching and draining the flush line at the quick disconnect, depressing the two Pres-Loc fasteners, and by pulling the carrying handle, the tank is easily removed for servicing.

### 3. Operation

The flush cycle is initiated by pressing the PRESS TO FLUSH button on the seat and shroud assembly. The push button switch applies 24-28 volt DC power to the motor section of the motor and pump assembly. Flushing continues until the push button is released. During the flush cycle, flushing fluid is pumped from the waste tank to the bowl by the self-priming pump section of the motor and pump assembly. The flush fluid enters the bowl through a nozzle in the upper rim and washes the inner surface of the bowl in a swirling pattern. Waste is carried to the waste tank through the knife valve below the bowl. When desired, the removable waste tank may be removed from the toilet for servicing after closing the knife valve.

## Monogram Sanitation

### LEADING PARTICULARS AND SERVING

#### 1. Leading Particulars

Use . . . . . Aircraft Toilet Facilities  
Electrical Power Requirement . . . . . 24-28 VDC, 7.5 Amps Max.  
Pump Type . . . . . Self-priming, Vane  
Fluid Pump Rating (Nominal) . . . . . 5 GPM  
Flush Cycle . . . . . Continuous (with flush  
switch depressed)

#### 2. Servicing Instructions

**WARNING:** FOR SANITARY REASONS, ALWAYS WEAR RUBBER GLOVES  
(ELBOW LENGTH) WHILE SERVICING OR WHEN HANDLING  
PARTS WHICH HAVE BEEN IN CONTACT WITH THE FLUSHING  
FLUID.

The toilet should be serviced during routine ground maintenance of the aircraft following any usage. It is more efficient and convenient to remove, clean and recharge the toilet tank on a regular basis than to wait until the tank is filled to capacity. If the tank becomes filled above the knife valve, follow the instructions below:

**NOTE:** To avoid spillage, do not remove tank when the fluid level is above the knife valve.

- (a) Hold a small paper or plastic cup against the bowl interior (preferably at the bowl flush ring outlet).
- (b) Depress the "Push to Flush" button to circulate flushing fluid.
- (c) Pour the flushing fluid into a bucket until the fluid level is below the knife valve.

## Monogram Sanitation

### A. Initial Precharge

The removable tank is to be precharged with a mixture of 2 quarts of water and 1 dissolvable package of germicidal deodorant, Monogram's Chemkare.

### B. Servicing the Toilet

Instructions for servicing are provided on a decal applied to the front side of the removable tank. Instructions are as follows:

#### (1) Tank Removal

- (a) Open front access to the toilet, as applicable, to remove the toilet tank.
- (b) Depress the lock ring of the flush hose quick disconnect coupling located on the right side at the front of the tank top.
- (c) Drain any residue of flush fluid in the hose by partially disengaging the plug from the quick disconnect and manipulating the hose to assist drainage.
- (d) Remove the flush hose from the quick disconnect and place hose in the retaining clip located on the underside of the toilet mounting plate.
- (e) Install the plug attached to the quick disconnect to seal the coupling.
- (f) Close the knife valve at the bottom of the toilet bowl by pushing the actuator handle until the valve is fully closed.
- (g) Press the two Pres-Loc fasteners on each side of the knife valve actuator to unlock the tank.
- (h) Remove the tank by pulling the recessed carrying handle on the tank top.

## Monogram Sanitation

### (2) Tank Cleaning

- (a) Remove cap from the pour spout to dispose of tank contents in a sewer or toilet. On earlier models without the pour spout, dispose of tank contents by holding the tank upside-down over a sewer or toilet and pull the knife valve actuator handle, opening the valve and allowing the tank to drain.
- (b) Rinse the tank by filling one-half full with water. Close the knife valve and shake vigorously. Drain tank as in previous step (a).

NOTE: Commercial detergents and disinfectants can be included in the rinse water if desired. However, do not include these materials in the tank precharge.

- (c) Rinse and drain the tank several times to ensure that the tank is thoroughly clean.
- (d) Wipe the exterior surfaces of the tank using a cloth moistened with clear water and disinfectant.

### (3) Tank Recharge

- (a) Charge the tank with a mixture of 2 quarts of water and 1 dissolvable package of Monogram's Chemkare chemical.

NOTE: To assure toilet recirculation system operation during freezing weather, an ethylene glycol base anti-freeze containing anti-foam agent may be added to the flush fluid.

## Monogram Sanitation

### (4) Tank Installation

- (a) Re-install the tank by inserting the slides located on each side of the knife valve into the slide plate assembly on the bottom of the toilet bowl and slide tank into place.
- (b) Press the two Pres-Loc fasteners to the first detente to secure the tank.
- (c) Remove the plug in the flush hose quick disconnect and connect the hose coupling to the quick disconnect. Lock the disconnect lock ring.
- (d) Pull the knife valve actuator to fully open the valve.
- (e) Lift the toilet seat and shroud assy from the top of the toilet and wipe with cloth moistened with clear water and disinfectant. Wipe the bowl and surrounding area.
- (f) Check flushing operation of the toilet and check for leaks.
- (g) Close access to the toilet.



## Monogram Sanitation

### TROUBLE SHOOTING AND MAINTENANCE

#### 1. Troubleshooting

Unless the toilet has been suitable tagged to denote the nature of maintenance requirements, refer to the Troubleshooting Chart as necessary to isolate and identify possible troubles.

TROUBLE	PROBABLE CAUSE	CORRECTIVE ACTION
Toilet will not operate	Electrical power not applied (24-28 VDC)	Check aircraft power, fuse/circuit breaker, electrical connection
	Defective wiring	Check wiring continuity
	Defective flush switch (push button)	Replace flush switch
Toilet operates but flush fluid not pumped into bowl	Defective motor	Replace motor and pump assy
	Inadequate flush fluid charge in tank	Charge toilet tank. Refer to Servicing Instructions
	Defective pump	Replace motor and pump assy
	Bowl nozzle, connecting hoses or strainer in tank clogged	Remove obstruction. Back flush to clean strainer. Refer to Cleaning.
	Flush (suction) hose not connected to tank quick disconnect	Connect hose to quick disconnect coupling

MM-170  
 Page 7  
 Nov 20/90

### Monogram Sanitation

TROUBLE	PROBABLE CAUSE	CORRECTIVE ACTION
Excessive noise during operation	Defective motor or pump	Replace motor and pump assy
	Strainer in tank clogged	Clean strainer (back flush)
Toilet has excessive odor	Excessive usage	Service toilet. Refer to Servicing Instructions
	Improper deodorant/chemical used	Use recommended chemical. Monogram Chemkare

## Monogram Sanitation

### 2. Cleaning

The following methods should be used for cleaning the toilet before disassembly and also for cleaning the disassembled components. Use specified cleaning agents.

#### A. Back Flushing the Tank

Back flush the toilet tank to clean the strainer inside the tank by connecting a water hose to the quick disconnect coupling on the tank top.

#### B. Cleaning Procedure

- (1) The toilet should be cleaned manually using a strong solution of hot soapy water and disinfectant. Rinse thoroughly with clean water and dry completely with a cloth and warm dry air.
- (2) Wash all mechanical parts in a strong solution of hot soapy water and disinfectant.

WARNING: WHEN USING TRICHLOROETHYLENE, WEAR SUITABLE PROTECTIVE GLOVES. TRICHLOROETHYLENE ABSORBS MOISTURE READILY AND CAN CAUSE SERIOUS BURNS WHEN IN PROLONGED CONTACT WITH THE SKIN.

- (3) Clean electrical parts manually, using cloth moistened sparingly with trichloroethylene.
- (4) Clean the tank and bowl manually, using a strong solution of disinfectant, hot soapy water and bristle brush. Scrub the flush channel in the upper rim of the bowl to remove buildup of deposits. Rinse thoroughly with clean hot water and dry completely.

ITEM	IDENTIFICATION	SOURCE
Disinfectant	Lysol (or equivalent)	Commercially available
Soap	All purpose liquid soap	Commercially available
Trichloroethylene	Federal Specification O-T-634C	Any approved source

## Monogram Sanitation

### 3. Repair

Only a worn or damaged component should be removed from the toilet tank. Unnecessary disassembly is not recommended. The instructions which follow are provided to disassemble the components of the toilet into their respective detail parts in order to repair or replace an item. Refer to the Illustrated Parts List section for description and identification of detail parts.

- A. Item numbers appearing on the exploded view illustrations have been assigned in a typical order of disassembly. Disassemble only to the extent necessary to repair or replace a part.
- B. Follow the standard shop practice for inspection of detail parts.
- C. Using an ohmmeter, check circuit continuity with the flush button depressed. The motor windings should exhibit a low resistive circuit (3 ohms max).
- D. Any necessary soldering is confined to electrical connections only using SN60WARP2 solder. See the toilet wiring diagram.
- E. Repair of the toilet is confined to replacement of damaged or worn components, except that minor scratches can be repaired in accordance with standard shop practices.
- F. Replace any item found to be damaged or worn. Replace all gaskets, seals, packings and rubber items.
- G. Reassemble the toilet in the reverse order of disassembly with particular attention to the following:

**CAUTION:** The toilet mounting plate and tank top are honeycomb panel construction. To prevent compression damage, do not over torque hardware when attaching any component to these items.

- (1) Bond new bowl gasket in place using Scotch Grip 1300 rubber adhesive (Minnesota Mining and Manufacturing Co.)

## Monogram Sanitation

- (2) Bond new knife valve seals in place using Uralane 5738 A/BX epoxy adhesive (Furane Plastics, Inc.)
  - (3) Apply Grade C locking compound (Loctite Corp.) to the threads of two No. 8 pan head screws (MS51957-46). Wipe excess compound from screws and install.
  - (4) Install new motor and pump assembly to the toilet mounting plate as follows:
    - (a) Remove the two No. 8 slotted head screws and the two No. 10 hex head bolts from the pump cover.
    - (b) Discard the cover and the two slotted head screws.

NOTE: Do not disassemble the motor and pump assembly except to remove cover.
    - (c) Install the unit to the mounting plate using the two No. 10 hex head bolts (NAS501-3H20A). Lockwire the bolts using MS20995C20 lockwire.
    - (d) Apply Grade C locking compound (Loctite Corp.) to the threads of two No. 8 pan head screws (MS51957-46). Wipe excess compound from screws and install.
    - (e) Connect the motor leads to the leads of the flush switch harness (Black to Black, Orange to Red). See the wiring diagram.
- H. When assembly is completed, perform a functional check of the toilet as follows:
- (1) Connect 24-28 VDC power to the toilet. See the wiring diagram for connection.
  - (2) Pour approximately 2 quarts of water into the toilet tank through the bowl.
  - (3) Press and hold the flush button. The flushing action should continue until the button is released. The swirl pattern should be consistent and vigorous, washing the complete inner surface of the bowl.

### Monogram Sanitation

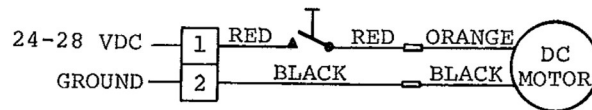

Wiring Diagram

## **12.0 SERVICE INSTRUCTIONS FOR OXYGEN SYSTEM**

### **PASSENGER OXYGEN MASK AND CONTAINER INSPECTION (AUTODEPLOYMENT OXYGEN SYSTEM)**

It is recommended that the passenger oxygen masks be inspected at the proper interval (See Section 2.0)

Check that none of the following exist:

- a. The oxygen mask sticks to the container or to itself.
- b. Contamination of the oxygen mask or the container.
- c. Excessive force (over four pounds) to remove lanyard pin.
- d. Improper installation of lanyard pin in valve actuator.
- e. Tears, cracks or deterioration of the mask or reservoir bag (unfold bag if necessary).
- f. Hose linking.
- g. Improper connection of oxygen hose to oxygen outlet.

### **PASSENGER OXYGEN MASK CLEANING (AUTODEPLOYMENT OXYGEN SYSTEM)**

Should the oxygen masks need cleaning, wipe the surface to be cleaned with a clean, soft, lint-free cloth that has been moistened with a mild detergent and warm solution (not to exceed 110° F; 43° C). Rinse thoroughly with clean water and allow to completely air dry.

#### **NOTE**

Isopropyl alcohol (3, Chart 1) can also be used for cleaning as well as for disinfecting. Refer to CABIN OXYGEN MASK AND CONTAINER DISINFECTING.

### **PASSENGER OXYGEN MASK AND CONTAINER DISINFECTING (AUTODEPLOYMENT OXYGEN SYSTEM)**

- a. Clean the mask and container as instructed in CABIN OXYGEN MASK CLEANING.
- b. Disinfect the mask and container with an aqueous solution of zephiran chloride (5, Chart 1), disinfectant (4, Chart 1) or isopropyl alcohol (3, Chart 1).
- c. Use a clean, lint-free cloth moistened with a solution per step b. Wipe quickly and lightly over the entire area.
- d. After disinfecting, thoroughly air dry the mask or container.
- e. After drying, lightly dust the outside of the face piece with neo-novacite (6, Chart 1).
- f. Install passenger mask in container per PASSENGER OXYGEN MASK PACKING.

## **PASSENGER OXYGEN MASK PACKING (AUTODEPLOYMENT OXYGEN SYSTEM)**

### **WARNING**

**Packing and installation of the passenger masks shall be performed by personnel familiar with the procedures and warnings presented in these instructions. Failure to properly pack and install the passenger masks can result in damage to the mask or failure of the mask to deploy properly.**

**All procedures describe in these instructions shall be performed in an area free of oil, grease, flammable solvents or other contaminants.**

- a. Inspect the mask and container as instructed in PASSENGER OXYGEN MASK AND CONTAINER INSPECTION.
- b. Fold the outside thirds of the reservoir bag over the center third.
- c. Place the head strap inside the face piece. Then fold the reservoir bag into the face piece on top of the head strap.
- d. Coil the oxygen hose on top of the reservoir bag.
- e. If disconnected, connect the end of the oxygen hose to the valve outlet.
- f. Install the lanyard pin in the valve actuator.
- g. Place the mask in the container with the coiled hose on top.

## **OXYGEN SYSTEM PLUMBING MAINTENANCE**

When oxygen lines are being connected, the first three male (external) threads of the fittings should be wrapped with anti-seize tape (1, Chart 1) prior to being connected back into the system.

When the oxygen system plumbing has been connected after maintenance, the new connections should be checked for leakage by applying leak detector fluid (2, Chart 1) to the connections and pressurized. Wipe dry immediately after testing.

When connections leak, check that they are tightened to the proper torque value for that fitting. If this does not stop the leakage, disassemble the connection and check all mating surfaces for damage. Smooth rough mating surfaces if possible to provide a tight connection or install new fittings.



## **CABIN SECTION OXYGEN MASK FLOW CHECK**

- a. Pull out the PULL ON SYSTEM READY control knob located on the left side of the pedestal.
- b. Wait 25 to 30 seconds for the system to load. Then pull out the PASSENGER MANUAL DROP OUT control knob located on the right side of the pedestal. The passenger oxygen masks should drop out of their containers.
- c. Individually check each passenger mask for flow by removing the lanyard pin located in the mask container assembly and observing the mas flow indicator. If flow is indicated reinstall the lanyard pin and check the next mask. If flow in not indicated mark the mask for replacement.
- d. Push in the PASSENGER MANUAL DROP OUT control knob.
- e. Push in the PULL ON SYSTEM READY control knob.
- f. Replace any oxygen masks that have been marked for replacement.
- g. Stow the masks and close the contianers.

### **CHART 1**

#### **RECOMMENDED MATERIALS**

MATERIAL	SPECIFICATION	PRODUCT	SUPPLIER
1. Tape, anti-seize, polytetrafluoroethylene	MIL-T27730		Obtain locally
2. Leak Detector Fluid, Oxygen System	MIL-L-25567		Obtain locally
3. Isopropyl	TT-I-735		Obtain locally
4. Disinfectant, Oxygen system		QS4	Brulin and Co., Inc. 2920 Dr. Andrew J. Brown Ave. PO Box 270 Indianapolis, IN 46206
5. Zephiran Chloride		00-2572	Scott Aviation 123 E. Montecito Ave. Sierra Madre, CA 91024
6. Neo-novacite		00736	Scott Aviation 123 E. Montecito Ave. Sierra Madre, CA 91024